

# BaBylissPRO®

©2023 BabylissPro

Distributed by:

**Dateline Imports P/L**  
**Professional Products Division**  
Banksmeadow, NSW 2019  
Australia

Ph: 61 2 9666 3611

[www.babylisspro.com.au](http://www.babylisspro.com.au)

**Dateline Imports NZ Ltd**  
66 Apollo Drive  
Albany, Auckland  
NZ 0632

Ph: 64 9 415 5415

[www.babylisspro.co.nz](http://www.babylisspro.co.nz)



## UVFOIL

Operating Instructions  
**UV-DISINFECTING**  
**METAL**  
**DOUBLE-FOIL**  
**SHAVER**

Model BLFS2A

For your safety and continued enjoyment of this product,  
always read the instruction book carefully before using.

**UV-DISINFECTING CAP KILLS 99.9% OF BACTERIA. BASED ON TESTING OF E. COLI, STAPHYLOCOCCUS AUREUS, AND PSEUDOMONAS AERUGINOSA WHEN USED IN ACCORDANCE WITH DIRECTIONS FOR USE BELOW.**

**IMPORTANT SAFETY INSTRUCTIONS**

**WARNING** – Polythene bags over product or package may be dangerous. To avoid danger of suffocation, keep this wrapper away from babies and children. This bag is not a toy.

When using electrical appliances, especially when children are present, basic safety precautions are required to always be followed, including the following:

**SAFETY CAUTIONS**

- For the purposes of recharging the battery, only use the adaptor provided with this appliance.
- This appliance is not intended for use by persons (including children) with reduced physical, sensory or mental capabilities, or lack of experience and knowledge, unless they have been given supervision or instruction concerning use of the appliance by a person responsible for their safety.
- Keep oil out of reach of children.
- Children should be supervised to ensure that they do not play with the appliance.
- The battery is not replaceable.
- This appliance contains batteries that are only replaceable by skilled persons.
- The appliance is only to be used with

the power supply unit provided with the appliance.

- The appliance must only be supplied at Safety Extra Low Voltage corresponding to the marking on the appliance.
- Do not immerse into water or other liquids. Do not use near basins or other vessels containing water.
- Store out of children's reach.
- If the supply cord is damaged, it must be replaced by a special cord or assembly available from the manufacturer or its service agent.
- Return the appliance to the nearest service facility for examination, electrical or mechanical adjustment or repair.
- Avoid skin contact with moving blade.
- Always ensure that the voltage to be used corresponds to the voltage marked on the unit.
- For additional protection, the installation of residual current device (RCD) with a rated operating current not exceeding 30mA is available in the electrical circuit supplying the bathroom. Ask your installer for advice.
- Do not use the appliance if it has been dropped or if it shows noticeable damage.
- Do not leave unattended when switched on and always allow to cool before storing away.
- Do not use any attachments other than those recommended by BabylissPRO.



**WARNING: Keep the appliance dry**

This symbol  indicates there is a detachable power supply.

**OPERATING INSTRUCTIONS**

1. Before using the shaver cordless for the first time, charge continuously for 4 hours. Maximum battery capacity will only be reached after 3 charging and discharging cycles. A full charge will provide over 5.5 hours of use.
2. Make sure the switch on the shaver is in the OFF (O) position.

Connect the standard charging cord (included) into the standard port on the bottom of the shaver. Plug the adaptor into any electrical outlet (at the voltage listed on the label affixed to the adaptor). If using the USB-C port for charging, make sure shaver is turned off and plug USB-C cable into the USB-C port at the bottom of the shaver.

Charging indicator will light up to indicate that the charging has begun. Charging is complete after 4 hours.

**BATTERY/CHARGING INDICATOR (BOTTOM OF SHAVER)**

Blue Flashing – Charging  
Blue Solid – Charge Complete, Fully Charged

3. The adaptor may become warm while charging. This is normal.
4. Preserving the battery: In order to maintain the optimum capacity of the rechargeable battery, the shaver should be recharged for 4 hours approximately every 6 months.
5. Make sure the switch is in the OFF (O) position when the shaver is not operating.
6. Only use the adaptor (CA78M) supplied with this appliance.

**WARNING:** If the charging light suddenly starts to flash rapidly, the appliance is faulty. If this happens, stop charging, remove the adapter from the outlet and contact our Customer Care Center for further advice (see the Warranty section of this information booklet).

**FOR DIRECT PLUG-IN OPERATION**

Make sure shaver is turned off. Connect standard charging cord into the standard port at the bottom of the shaver. The shaver will not operate directly plugged in via USB-C. Direct plug-in operation is only possible through the standard charging cable, not USB-C.

**ON/OFF SWITCH**

To operate, simply slide switch to the ON (I) position. To stop operation, set to the OFF (O) position.

**UV DISINFECTING CAP – DIRECTIONS FOR USE:**

**BLUE UV LOGO (TOP CAP OF SHAVER)**  
BLUE LED ON – Sanitizing in Process  
BLUE LED OFF – Sanitizing Complete/Unit Off

1. Close the cap and the sanitizing process will immediately start. The lid must be fully closed for the UV-sanitizing process to begin. The blue UV light indicator will illuminate indicating the ultraviolet sanitizing process is in operation.
2. Wait 3 minutes for the cycle to complete. The blue light will turn off when the cycle is done.

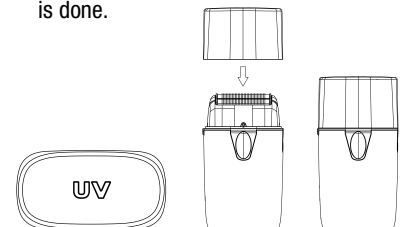

**VERY IMPORTANT:**

Cutters must be cleaned and oiled on a regular basis for proper functioning. Failure to regularly clean and oil the cutters will void the warranty.

**BASIC INSTRUCTIONS FOR USE**

1. Men whose skin is sensitive or easily irritated by shaving, or who suffer from a skin allergy, should test the shaver on one section of the leg or arm before using it.
2. Remove the UV-disinfecting cap and turn on the unit to start shaving. Hold the shaver at a right angle to the area that you want to shave and run the double shaving foil carefully along your skin. Tip: In general, we recommend that you shave against the direction of hair growth, as this is the best way to trim the hair. Pull your skin tight with your fingers in inaccessible areas to achieve optimum results.
3. Switch the shaver off each time after shaving and clean it.
4. Do not push the shaver on the skin too hard, as this could cause irritation, make the shaver warm and prevent a perfect shave.
5. Please note that it takes 2 to 4 weeks for your skin to adapt to a shaver, so do not change shaving instruments during this period of time.
6. If hair is longer than 0.8mm (1/32"), begin by cutting the hair down first with a trimmer, then use shaver for a smooth, close shave.

**USER MAINTENANCE INSTRUCTIONS  
TAKING CARE OF YOUR SHAVER**

Do not remove the shaving foil head while the shaver is switched on. Always switch the shaver off!

Ensure that no water gets into the inside of the shaver to avoid the risk of an electric shock when it is back in operation.

Never press on the cutters or the shaving foil and do not touch them with hard objects as this can cause irreparable damage to the shaver or parts.

Be careful when dealing with the blades, as they are very sharp. Risk of injury!

When cleaning, do not apply any detergents or scouring agents and do not use any abrasive or sharp objects. They can cause irreparable damage to the shaver.

**NOTE:** When cleaning your shaver, make sure the unit is turned off.

**CAUTION:**

- **DO NOT** run shaver, cutters or disinfecting cap under water. Use only the small brush (included) to clean the cutters.
- To clean the external surfaces of the shaver, use a damp cloth. **DO NOT APPLY ANY DETERGENTS.**
- To dry, wipe the surface of the shaver with a dry towel. Do not use a hair dryer or heater to dry the shaver.
- The shaver should not be used until it has completely dried.
- Be sure voltage is correct before plugging in. For connection to power supply not in Australia abroad use an attachment plug adapter of the proper configuration for power outlet. The included adapter automatically adjusts to the input voltage. **DO NOT USE A VOLTAGE CONVERTER.**

**NOTE:** Always replace the cutters and foil head assembly at the same time.

**TO REPLACE FOIL HEAD ASSEMBLY**

1. Remove the foil head assembly by pressing the round release button located on the side of the shaver. Hold the foil head assembly on both sides and lightly pull away from shaver unit.
2. Take the replacement foil head assembly (FXLRF2) out of package. Align the replacement foil head assembly over the cutters. Carefully move the replacement foil head assembly down toward the shaver unit until it firmly snaps into place. **BE CAREFUL NOT TO DAMAGE THE FOILS OR CUTTERS WHILE INSTALLING.**

**TO REPLACE CUTTERS**

1. First remove foil head assembly. Then remove one cutter by placing your fingers on each side of it and gently pulling up and away from the drive shaft. Repeat with second cutter.
2. Remove the new cutters (FXLRF2) from the packaging. Align one cutter above a drive shaft and lightly push down until it snaps into place. Repeat with second cutter.
3. Replace the foil head assembly, turn shaver on to ensure it is working properly.

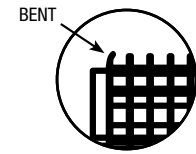
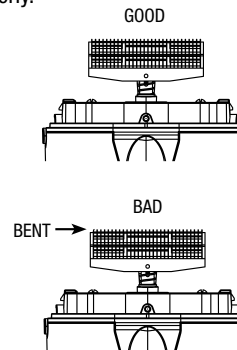
**DAILY MAINTENANCE:**

1. First remove disinfecting cap from shaver. Then press the release button on the side of shaver and remove the foil head assembly (see Figs. 1 & 2).
2. Use cleaning brush to whisk away any debris on and around cutter (See Fig. 3).
3. Snap the head assembly closed (see Fig. 4).

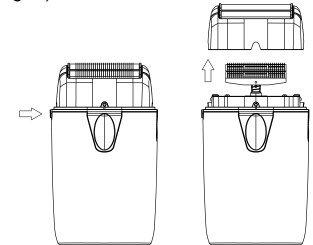

Fig. 1

Fig. 2

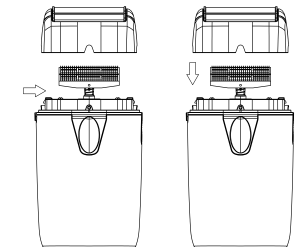

Fig. 3

Fig. 4

**WEEKLY MAINTENANCE:**

1. Repeat steps 1 – 3 from the Daily Maintenance cleaning steps.

- Rinse the head of the shaver under running water (see Fig. 5). NEVER submerge the shaver in water.

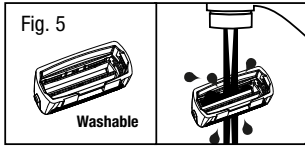

- Leave head open for drying.
- Press the shaver head back into place (see Fig. 4).
- Leave head open for drying.
- Make sure that the UV-disinfecting cap electrical contacts are clean, using alcohol to clean any debris or buildup. DO NOT rinse the disinfecting cap under water.

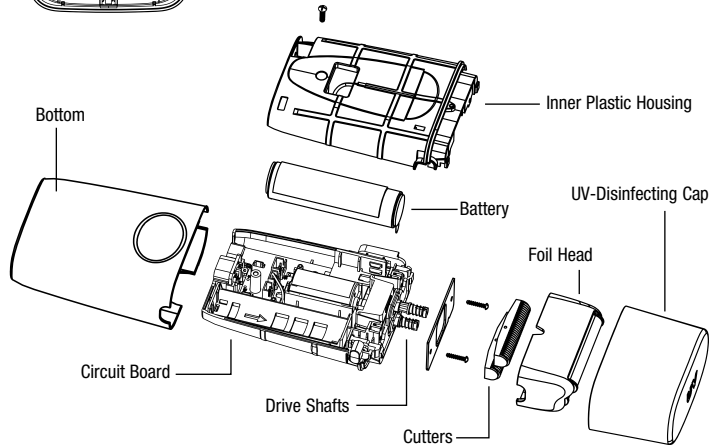
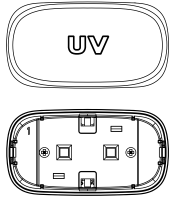

### BATTERY REMOVAL

This shaver contains lithium-ion batteries. To help protect our environment, the lithium-ion batteries should be removed for safe disposal at the end of the shaver's life. Please take the appliance to a recycling center, where the internal rechargeable battery should be removed and recycled separately.



**Li-ion**

For more information about recycling of electrical and battery operated appliance, please contact your local office or your household waste disposal service.

## BLFS2A UV-DISINFECTING METAL DOUBLE-FOIL SHAVER



## TWO YEAR WARRANTY

The warranty may only be claimed where proof of original purchase is presented, i.e. original purchase receipt or invoice. We recommend attaching a copy of your purchase receipt to this instruction book and storing in a safe place.

To make a warranty claim you can return the defective product back to the place it was purchased where it will be replaced, exchanged or repaired (see point 12 in conditions).

Trade purchasers who have purchased from us directly should contact us directly with regard to warranty claims.

Please have the following details to hand:

1. Date of purchase
2. Details of where the product was purchased
3. Product Name/Model Number
4. Confirm you have your purchase receipt
5. Detail the problem with your product

**It is important to retain your proof of purchase. We recommend attaching your receipt to this page.**

For advice with regard to the warranty claim process please contact Customer Service:

### **Dateline Imports P/L Professional Products Division**

Banksmeadow, NSW 2019

Australia

Ph: 61 2 9666 3611

[www.babylisspro.com.au](http://www.babylisspro.com.au)

### **Dateline Imports NZ Ltd**

66 Apollo Drive

Albany, Auckland

NZ 0632

Ph: 64 9 415 5415

[www.babylisspro.co.nz](http://www.babylisspro.co.nz)

## WARRANTY AGAINST DEFECTS

### A. AUSTRALIAN CONSUMER LAW

1. Our goods come with guarantees that cannot be excluded under the Australian Consumer Law. You are entitled to a replacement or refund for a major failure and compensation for any other reasonably foreseeable loss or damage. You are also entitled to have the goods repaired or replaced if the goods fail to be of acceptable quality and the failure does not amount to a major failure.
2. The guarantees under the Australian Consumer Law ("ACL") are provided in sections 51 to 59 inclusive of the ACL ("Statutory Guarantees") and the remedies are provided in sections 259 to 266 inclusive of the ACL ("Statutory Remedies").

In New Zealand our goods come with a guarantee that cannot be excluded under the Consumer Guarantee Act 1993.

### B. BabylissPRO EXTENDED WARRANTY

1. In addition and subject to the Statutory Guarantees and Statutory Remedies, the following express warranty ("Warranty") commences from the date of purchase and continues for a period of 24 months ("Warranty Period") after which it expires. Subject to the conditions in Section C below, Dateline warrants to the original purchaser ("Purchaser") of the BabylissPRO product that is the subject of this warranty ("Product") that if during the Warranty Period, the Product suffers from any defect caused by faults in materials or workmanship, Dateline will a) replace the Product, or b) exchange defective part in the Product or c) repair the Product, as Dateline may choose in its discretion

("Warranty"). In this Warranty "Dateline" means Dateline Imports P/L (ABN 60 000 557 282) of Banksmeadow, NSW 2019, Australia.

2. To honour the Warranty, Dateline must replace, or exchange parts in, or repair, the Product, as Dateline determines, in accordance with paragraph B1 above, subject always to the conditions in Section C below.
3. If any of the conditions in Section C below are inconsistent with any provisions of the ACL or regulations made there under, those provisions of the ACL or regulations shall prevail to the extent of the inconsistency.

### C. CONDITIONS

1. The Product must be used in accordance with manufacturer's instructions. This Warranty does not apply should the defect in or failure of the Product be attributable to misuse, abuse, accident, act of God such as lightning, or nonobservance of manufacturer's instructions on the part of the user. This Warranty does not cover ordinary wear and tear in the Product or its parts.
2. Dateline does not accept liability for a) any loss or damage however suffered, caused by or arising out of any failure to use the Product in accordance with the manufacturer's instructions, and b) any indirect, consequential or economic loss or damage however caused.
3. This Warranty is immediately void if – a) any serial number or appliance plate is removed or defaced, b) the Product has been serviced or otherwise repaired by a person not authorized to do so

by Dateline or where non approved replacement parts are used.

4. The Product must be connected to the electrical voltage supply as specified in the ratings label located on the Product. This Warranty does not cover defects arising from incorrect voltage supply.
5. This Warranty may only be claimed against where proof of original purchase is presented, for example, original receipt or invoice.
6. Any parts of the Product that need to be replaced, or if the whole Product needs to be replaced, the replaced Product, become the property of Dateline. The Warranty on any replacement Product or parts will expire on the same date that the Warranty Period on the original Product expires.
7. The benefits provided by this Warranty are in addition to all other rights and remedies in respect of the Product which the Purchaser has under the ACL, and applicable laws in New Zealand, which rights and remedies by law may not be excluded. All other warranties and representations express and implied are hereby excluded.
8. The defect must have occurred during the Warranty Period and Purchaser bears the onus of proving that fact, and that the defect was not caused by any of the causes excluded from this Warranty.
9. This Warranty does not cover Products purchased from any person who is not a retailer serviced by Dateline Imports P/L or purchased second hand.
10. The Purchaser is responsible for all postage and freight charges and any other expenses incidental to claiming against this Warranty.

11. The Warranty excludes consumable items (such as blades or brushes) and normal wear and tear.
12. If you're certain your product is defective, and the product is covered by the terms of this warranty, you need to take the product back to the place you purchased it from, where the retailer will replace the product for you, exchange defective parts, repair the Product or refund at Dateline's discretion. In this event, per the terms of this warranty you will need to present this portion of the warranty information and the purchase receipt as proof of purchase so please make sure you keep both these instructions and your receipt on hand for the duration of the warranty period.