

BaBylissPRO®

©2023 BabyLissPro

Distributed by:

Dateline Imports P/L
Professional Products Division
Banksmeadow, NSW 2019
Australia

Ph: 61 2 9666 3611

www.babylisspro.com.au

Dateline Imports NZ Ltd
66 Apollo Drive
Albany, Auckland
NZ 0632

Ph: 64 9 415 5415

www.babylisspro.co.nz



Operating Instructions

**DUAL INTERCHANGEABLE
LITHIUM BATTERY TRIMMER**

Model B797A SERIES

For your safety and continued enjoyment of this product,
always read the instruction book carefully before using.

B797A SERIES DUAL INTERCHANGEABLE LITHIUM BATTERY TRIMMER

IMPORTANT SAFETY INSTRUCTIONS

When using electrical appliances, especially when children are present, basic safety precautions are required to always be followed, including the following:

READ ALL INSTRUCTIONS BEFORE USING KEEP AWAY FROM WATER

SAFETY CAUTIONS

- For the purposes of recharging the battery, only use the adapter provided with this appliance.
- This appliance is not intended for use by persons (including children) with reduced physical, sensory or mental capabilities, or lack of experience and knowledge, unless they have been given supervision or instruction concerning use of the appliance by a person responsible for their safety.
- Keep oil out of reach of children.
- Children should be supervised to ensure that they do not play with the appliance.
- The battery is not replaceable.
- This appliance contains batteries that are only replaceable by skilled persons.
- Store out of children's reach.
- If the supply cord is damaged, it must be replaced by a special cord or assembly available from the manufacturer or its service agent.
- Return the appliance to the nearest service facility for examination, electrical

or mechanical adjustment or repair.

- Avoid skin contact with moving blade.
- Always ensure that the voltage to be used corresponds to the voltage marked on the unit.
- For additional protection, the installation of residual current device (RCD) with a rated operating current not exceeding 30ma is available in the electrical circuit supplying the bathroom. Ask your installer for advice.
- Do not use the appliance if it has been dropped or if it shows noticeable damage.
- Do not leave unattended when switched on and always allow to cool before storing away.
- Do not use any attachments other than those recommended by BabyLissPRO.

Keep the appliance dry

OPERATING INSTRUCTIONS

1. **Never leave a plugged-in appliance unattended.**
2. Close supervision is required when this appliance is used by, on, or near children, persons with limited physical, sensory, or mental capabilities or invalids.
3. Use appliance only for its intended use as described in this manual. Use only attachments recommended by the manufacturer. Do not use an extension cord to operate the appliance.
4. **Never operate the appliance if it has a damaged cord or plug, is not working properly, or has been dropped, damaged, or dropped into water. Return the appliance to a Service Center for examination and repair.**
5. Keep the appliance cord away from heated surfaces.

6. Do not pull, twist or wrap the cord around the appliance.
7. Never drop or insert any object into any opening on the appliance.
8. Do not place the trimmer on any surface while it is operating.
9. Do not use the trimmer with a damaged or broken comb or with teeth missing from the blades, as injury may result. Before each use, make certain the blades are aligned properly and oiled.
10. Make sure the switch is in the OFF position when the trimmer is not operating.
11. Do not use the appliance outdoors or where aerosol (spray) products are being used or where oxygen is being administered.
12. Do not crush, heat above 100°C or incinerate the appliance due to risk of fire, explosion or burns.
13. Plug charging stand into outlet to charge batteries. To disconnect, first remove batteries from charging stand, then unplug from outlet.
14. Use of a charging stand not sold by BaByLissPRO may result in risk of fire, electric shock, or injury to person.
15. Do not disassemble charging stand. Incorrect reassembly may result in a risk of electric shock or fire. When repair is required, send or take it to a Authorized Service Center.
16. The batteries for this trimmer are designed to provide maximum trouble-free life. However, like all batteries, they will eventually wear out. Do not attempt to replace the batteries. When replacement is required, contact a Authorized Service Center.
17. Batteries can be harmful to the environment if disposed of improperly. Many communities offer recycling or battery collection. Contact your local government about disposal practices in your area.

18. **WARNING:** Never touch both terminals on trimmer with metal objects and/or body parts, as short circuit may result. Keep away from children. Failure to comply with these warnings could result in fire or serious injury.
19. This trimmer is intended for trimming purposes only.
20. During use, do not place or leave the appliance where it is expected to be:
A) subject to damage by an animal or
B) exposed to the weather.

OPERATING INSTRUCTIONS

This product is for commercial use.

CHARGING STAND

To charge battery, plug charging stand into 100–240V AC, 50/60Hz electrical outlet or as noted on the unit. Place a battery into either pocket on the charging stand (or put a battery in each pocket). The battery has electrical contacts that touch electrical contacts in the charging stand. The weight of the battery unit will provide sufficient contact. Before using your trimmer for the first time, make sure the battery has been fully charged. Note that it is normal for the battery and charging stand to feel warm to the touch when charging.

AUTOMATIC CHARGING MANAGEMENT

One Battery – 2.4A Fast Charging
Two Batteries – 1.2A Normal Charging



Blue/Red LED Charging Indicators

Charging – Blue Flashing Light

(1 flash/4 seconds)

Fully Charged – Blue Light

Error – Red Flashing Light

(more than 4 flashes/second).

1. Before using the trimmer for the first time, charge battery continuously for 3 hours. Maximum battery capacity will only be reached after 3 charging and discharging cycles.

2. Plug the charging stand into any electrical outlet (at the voltage listed on the label affixed to the charging stand). The charging indicator will light up blue and start flashing to indicate that the charging has begun. Charging is complete after 3 hours — the light will go from flashing blue to a solid blue to indicate charging is complete.

3. The charging stand may become warm while charging. This is normal.

4. Preserving the batteries: In order to maintain the optimum capacity of the rechargeable batteries, the batteries should be recharged for 3 hours approximately every 6 months.

5. If the charging light starts to flash red rapidly (more than 4 flashes per second), the appliance is faulty. If this happens, stop charging by removing plug from the outlet and contact a Authorized Service Center.

6. To install or remove battery from trimmer, see Battery Removal and Installation in this manual.

ON/OFF SWITCH

To operate trimmer, simply slide switch to ON (marked “I”). To stop operation, set to the OFF (marked “O”) position.

VERY IMPORTANT: Blades must be cleaned and oiled on a regular basis for proper functioning. Failure to regularly clean and oil the blades will void the warranty.

BATTERY REMOVAL

- Battery must be removed from the appliance before it is recycled.
- The batteries must be recycled in accordance with the recycling standards for lithium-ion batteries.

This trimmer comes with two lithium-ion batteries, the lithium-ion batteries should be removed for safe disposal at the end of the trimmer's life.

Please take the appliance to a recycling center, where the internal rechargeable battery should be removed and recycled separately.



For more information about recycling of electrical and battery operated appliance, please contact your local office or your household waste disposal service.

REPLACING (REMOVING) BLADE SET

To remove the blade set, turn the trimmer to the OFF position and unplug it from the electrical outlet. Turn the trimmer upside down so that the teeth of the trimmer are facing down. Place the trimmer on a flat surface and using the screwdriver, loosen the fastening screws from the blade set. Remove the blade set from the trimmer (see Fig. 1).

Fig. 1

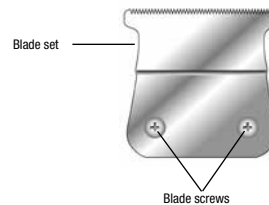

To install or replace your trimmer blade set, reverse the procedure, aligning the blade cushion shaft into the moving blade cushion (see Fig. 2). With the blade held in place, replace blade screws and tighten loosely. Turn the trimmer over and align the blade set parallel to the trimmer's upper housing.

Fig. 2

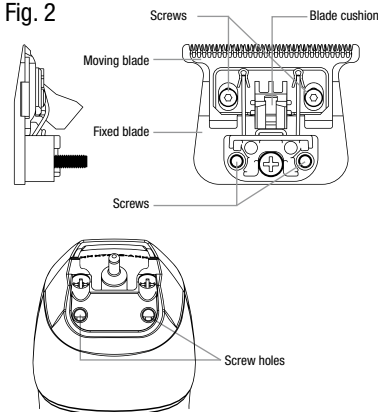

BLADE CARE

Because the trimmer blades are precision-made for a very special use, they should always be handled with care and cleaned regularly to ensure maximum performance. Each time you finish using the trimmer, take the cleaning brush provided and brush away any loose hair that has collected in the blades. Use a clean cloth to dry the attachment, reattach and then store the trimmer to protect the blades until the next use.

Any other servicing should be performed by an authorized service representative, since the appliance has no other user-serviceable parts. This product is for commercial use.

DO NOT RINSE BLADE OR TRIMMER HANDLE OR ADAPTER.

ZERO GAP ADJUSTMENT TOOL
IMPORTANT! Only ever attempt to zero gap the blades using the adjustment tool, following the instructions very precisely.

The adjustment tool is required to adjust the blades to zero gap, to achieve a closer, more precise cut.

Step 1 – Using the screwdriver included, gently loosen the two small screws on each side of the blade.



Step 2 – Slide the zero gap tool over the gold fixed blade until it is tight against the back portion of the moving cutting blade.

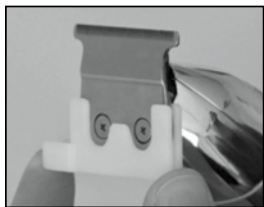

Step 3 – Using your fingers on each side of the zero gap tool, push up until the black cutting blade is even with “or” slightly below the gold fixed blade.



Be sure that the blades are aligned properly. The teeth of the smaller blade (cutter) should rest slightly below the upper edge of the larger blade (comb) approximately 1/64" to 1/32" apart (see Fig. 3). If the blades are not correctly aligned, they may cut or scratch your skin when trimming. Once the blades have been aligned, tighten the screws firmly.

Fig. 3

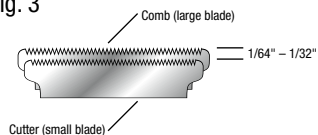

Step 4 – MAKE SURE THE MOVING CUTTING BLADE DOES NOT EXTEND PAST THE FIXED GOLD BLADE. **WARNING: IF THE CUTTING BLADE EXTENDS PAST THE FIXED BLADE YOU CAN POTENTIALLY CUT A CLIENT.**



Step 5 – Once the blade is adjusted to zero gap or your liking, gently tighten the two screws on each side of the blade while holding the zero gap tool in place. If the blade is not adjusted to satisfaction after testing, repeat the adjusting process.



HAIR POCKET DOOR

The top housing of the B797A trimmer has a removable, magnetic door integrated into the top housing, allowing for easy access to and cleaning of critical moving parts.

To remove the magnetic door, place fingers on the side tabs and pull straight away from the unit.

To clean internal moving parts, use compressed air or the included small cleaning brush to clear out hair from the housing after the magnetic door has been

removed.



Once finished with cleaning the moving parts of the trimmer unit, carefully place the magnetic door back in its proper position. The magnets should pull the door back into place.

BATTERY REMOVAL AND INSTALLATION

The B797A trimmer features removable and rechargeable batteries, so you can cut and style for extended amounts of time with minimal interruption.

Make sure the trimmer switch is in the OFF position before removing or installing battery.

To remove the battery, press on the two tabs toward the bottom of the unit and pull the battery out of the bottom of the unit. Then place into charging stand.

To install a new battery, line up the tabs of the charged battery with the slots on the sides of the unit and slide up into the housing, pressing firmly until battery clicks into place.



BATTERY (MODEL FXBPT) INDICATORS

- Critically Low Battery – Red Flashing Light
- Low Battery – Blue Flashing Light
- Unit On and Battery Fully Charged – Blue Light
- Error – Red Flashing Light (more than 4 flashes/second)

WARNING – Make sure battery tabs and slots on the sides of the unit are lined up before pushing battery all the way in. Do not force battery in if any resistance is felt.

B797A PRODUCT FEATURES

- High-Torque, 7200 RPM, Brushless Motor
- Dual Lithium Interchangeable Batteries
- Dual Battery Charging Stand
- Magnetic, Removable Hair Pocket Door
- LED Ring Light Battery Indicator
- All-Metal Housing / Knurled Barbell Grip
- Black DLC Deep-Tooth 360° Exposed T-Blade
- Zero-Gap Adjustable
- Detent Hanging Hook



ON/OFF switch (ON marked "I", OFF marked "O")

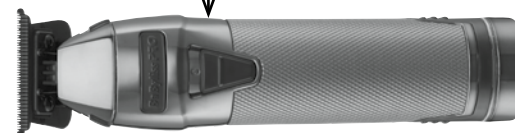

Before using the Class 2 Power supply, read these instructions carefully.

Rated input voltage: 100-240V ~, 50/60Hz 0.4A

Rated Output: 4.5V DC 2.5A 11.25W

OPERATION

1. For dry location use only. Do not expose to water.
2. When not in use, unplug unit completely.
3. Unit will become warm during operation.

CAUTION

1. Dry location use only. Do not expose to liquids, vapor, or rain.
2. Ensure jack is plugged into the clipper unit before plugging the adapter into the outlet.
3. Do not operate any appliance that has a damaged output cord or housing.
4. Always unplug the unit before cleaning or when not in use.
5. Be sure voltage is correct before plugging in. For connection to power supply not in Australia, use an attachment plug adapter of the proper configuration for power outlet. The included adapter automatically adjusts to the input voltage. DO NOT USE A VOLTAGE CONVERTER.

TRIMMER CHARGING PRECAUTIONS

- Avoid charging the batteries at temperatures below 5°C or above 35°C.
- Avoid charging the batteries in direct sunlight or near a radiating heat source.
- Even though the trimmer may not be used for an extended period, charge batteries for 3 hours approximately every 6 months to preserve battery life.
- The power cord cannot be replaced. If it is damaged, charging stand should be discarded.

TRIMMER / BATTERY OPERATING PRECAUTIONS

- This trimmer uses a removable rechargeable battery. Do not throw battery or trimmer into fire, apply heat, or charge, use, or leave in a high-temperature environment.

TWO YEAR WARRANTY

The warranty may only be claimed where proof of original purchase is presented, i.e. original purchase receipt or invoice. We recommend attaching a copy of your purchase receipt to this instruction book and storing in a safe place.

To make a warranty claim you can return the defective product back to the place it was purchased where it will be replaced, exchanged or repaired (see point 12 in conditions).

Trade purchasers who have purchased from us directly should contact us directly with regard to warranty claims.

Please have the following details to hand:

1. Date of purchase
2. Details of where the product was purchased
3. Product Name/Model Number
4. Confirm you have your purchase receipt
5. Detail the problem with your product

It is important to retain your proof of purchase. We recommend attaching your receipt to this page.

For advice with regard to the warranty claim process please contact Customer Services:

Dateline Imports P/L Professional Products Division

Banksmeadow, NSW 2019

Australia

Ph: 61 2 9666 3611

www.babylisspro.com.au

Dateline Imports NZ Ltd

66 Apollo Drive

Albany, Auckland

NZ 0632

Ph: 64 9 415 5415

www.babylisspro.co.nz

WARRANTY AGAINST DEFECTS

A. AUSTRALIAN CONSUMER LAW

1. Our goods come with guarantees that cannot be excluded under the Australian Consumer Law. You are entitled to a replacement or refund for a major failure and compensation for any other reasonably foreseeable loss or damage. You are also entitled to have the goods repaired or replaced if the goods fail to be of acceptable quality and the failure does not amount to a major failure. 2. The guarantees under the Australian Consumer Law ("ACL") are provided in sections 51 to 59 inclusive of the ACL ("Statutory Guarantees") and the remedies are provided in sections 259 to 266 inclusive of the ACL ("Statutory Remedies").

In New Zealand our goods come with a guarantee that cannot be excluded under the Consumer Guarantee Act 1993.

B. BabylissPRO EXTENDED WARRANTY

1. In addition and subject to the Statutory Guarantees and Statutory Remedies, the following express warranty ("Warranty") commences from the date of purchase and continues for a period of 24 months ("Warranty Period") after which it expires. Subject to the conditions in Section C below, Dateline warrants to the original purchaser ("Purchaser") of the BabylissPRO product that is the subject of this warranty ("Product") that if during the Warranty Period, the Product suffers from any defect caused by faults in materials or workmanship, Dateline will a) replace the Product, or b) exchange defective part in the Product or c) repair the Product, as Dateline may choose in its discretion

("Warranty"). In this Warranty "Dateline" means Dateline Imports P/L (ABN 60 000 557 282) of Banksmeadow, NSW 2019, Australia.

2. To honour the Warranty, Dateline must replace, or exchange parts in, or repair, the Product, as Dateline determines, in accordance with paragraph B1 above, subject always to the conditions in Section C below.
3. If any of the conditions in Section C below are inconsistent with any provisions of the ACL or regulations made there under, those provisions of the ACL or regulations shall prevail to the extent of the inconsistency.

C. CONDITIONS

1. The Product must be used in accordance with manufacturer's instructions. This Warranty does not apply should the defect in or failure of the Product be attributable to misuse, abuse, accident, act of God such as lightning, or nonobservance of manufacturer's instructions on the part of the user. This Warranty does not cover ordinary wear and tear in the Product or its parts.
2. Dateline does not accept liability for a) any loss or damage however suffered, caused by or arising out of any failure to use the Product in accordance with the manufacturer's instructions, and b) any indirect, consequential or economic loss or damage however caused.
3. This Warranty is immediately void if – a) any serial number or appliance plate is removed or defaced, b) the Product has been serviced or otherwise repaired by a person not authorized to do so

by Dateline or where non approved replacement parts are used.

4. The Product must be connected to the electrical voltage supply as specified in the ratings label located on the Product. This Warranty does not cover defects arising from incorrect voltage supply.
5. This Warranty may only be claimed against where proof of original purchase is presented, for example, original receipt or invoice.
6. Any parts of the Product that need to be replaced, or if the whole Product needs to be replaced, the replaced Product, become the property of Dateline. The Warranty on any replacement Product or parts will expire on the same date that the Warranty Period on the original Product expires.
7. The benefits provided by this Warranty are in addition to all other rights and remedies in respect of the Product which the Purchaser has under the ACL, and applicable laws in New Zealand, which rights and remedies by law may not be excluded. All other warranties and representations express and implied are hereby excluded.
8. The defect must have occurred during the Warranty Period and Purchaser bears the onus of proving that fact, and that the defect was not caused by any of the causes excluded from this Warranty.
9. This Warranty does not cover Products purchased from any person who is not a retailer serviced by Dateline Imports P/L or purchased second hand.
10. The Purchaser is responsible for all postage and freight charges and any other expenses incidental to claiming against this Warranty.

11. The Warranty excludes consumable items (such as blades or brushes) and normal wear and tear.
12. If you're certain your product is defective, and the product is covered by the terms of this warranty, you need to take the product back to the place you purchased it from, where the retailer will replace the product for you, exchange defective parts, repair the Product or refund at Dateline's discretion. In this event, per the terms of this warranty you will need to present this portion of the warranty information and the purchase receipt as proof of purchase so please make sure you keep both these instructions and your receipt on hand for the duration of the warranty period.