

©2024 BaBylissPRO

Distributed by:

**Dateline Imports P/L**

Professional Products Division  
Discovery Cove - Unit 8/1801 Botany Road  
Banksmeadow, NSW 2019  
Australia

Ph: 61 2 9666 3611

[www.babylisspro.com.au](http://www.babylisspro.com.au)

**Dateline Imports NZ Ltd**

66 Apollo Drive  
Albany, Auckland  
NZ 0632

Ph: 64 9 415 5415

[www.babylisspro.co.nz](http://www.babylisspro.co.nz)

# BaBylissPRO®



LO-PROFX 

Operating Instructions

**PROFESSIONAL  
INTERCHANGEABLE-  
BATTERY TRIMMER**

Model B729A

For your safety and continued enjoyment of this product,  
always read the instruction book carefully before using.

## PROFESSIONAL INTERCHANGEABLE-BATTERY TRIMMER

### IMPORTANT SAFETY INSTRUCTIONS

When using electrical appliances, especially when children are present, basic safety precautions are required to always be followed, including the following:

### READ ALL INSTRUCTIONS BEFORE USING KEEP AWAY FROM WATER

### SAFETY CAUTIONS

- For the purposes of recharging the battery, only use the adapter provided with this appliance.
- This appliance is not intended for use by persons (including children) with reduced physical, sensory or mental capabilities, or lack of experience and knowledge, unless they have been given supervision or instruction concerning use of the appliance by a person responsible for their safety.
- Keep oil out of reach of children.
- Children should be supervised to ensure that they do not play with the appliance.
- The battery is not replaceable.
- This appliance contains batteries that are only replaceable by skilled persons.
- Store out of children's reach.
- If the supply cord is damaged, it must be replaced by a special cord or assembly available from the manufacturer or its service agent.

- Return the appliance to the nearest service facility for examination, electrical or mechanical adjustment or repair.
- The appliance must only be supplied at safety extra-low voltage corresponding to the marking on the appliance.
- Do not immerse into water or other liquids. Do not use near basins or other vessels containing water. 
- For additional protection, the installation of residual current device (RCD) with a rated operating current not exceeding 30mA is available in the electrical circuit supplying the bathroom. Ask your installer for advice.

- Do not use the appliance if it has been dropped or if it shows noticeable damage.
- Do not leave unattended when switched on and always allow to cool before storing away.
- Do not use any attachments other than those recommended by BaBylissPRO.
- Do not use this appliance with damaged or broken foils, as injury may occur.
- The appliance is intended for commercial use.
- If the appliance is to be stored unused for a long period, the battery should be removed.
- It is a battery-operated appliance, the battery being charged outside the appliance.
- The supply terminals are not to be short-circuited.

**WARNING: Keep the appliance dry**

## OPERATING INSTRUCTIONS

This product is for commercial use.

### ON/OFF SWITCH

To operate trimmer, simply slide switch to the ON ("1") position. To stop operation, slide switch to the OFF ("0") position. Make sure the switch is in the OFF ("0") position when the trimmer is not being used.

**VERY IMPORTANT: Blades must be cleaned and oiled on a regular basis for proper functioning. Failure to regularly clean and oil the blades will void the warranty.**

### REPLACING (REMOVING) BLADE SET

To remove the blade set, turn the trimmer to the "0" (OFF) position. Turn the trimmer upside down so that the teeth of the trimmer are facing down. Place the trimmer on a flat surface and using the included screwdriver, loosen the fastening screws from the blade set. Remove the blade set from the trimmer (see Fig. 1).

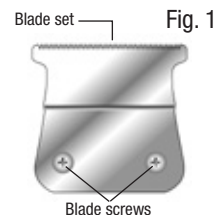

To install or replace your trimmer blade set, reverse the procedure, aligning the blade cushion shaft into the moving blade cushion (see Fig. 2). With the blade held in place, replace blade screws and loosely tighten. Turn the trimmer over and align the blade set parallel to the trimmer's upper housing.

Fig. 2

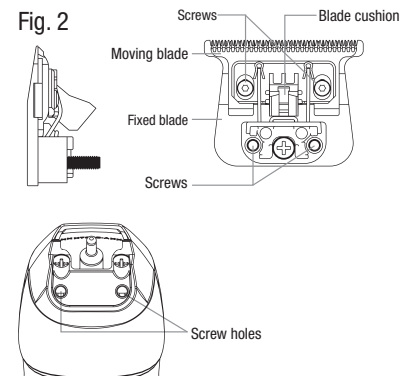

### BLADE CARE

Because the trimmer blades are precision-made for a very special use, they should always be handled with care and cleaned and oiled regularly to ensure maximum performance. Each time you finish using the trimmer, take the cleaning brush provided and brush away any loose hair that has collected in the blades. To oil, apply a few drops of oil to the blades and wipe off any excess oil with a dry cloth. Wipe the housing clean with a dry cloth. Any other servicing should be performed by an authorised service representative, since the appliance has no other user-serviceable parts. This product is for commercial use.

**DO NOT RINSE BLADE, TRIMMER, BATTERY, OR CHARGER**

**ZERO-GAP ADJUSTMENT TOOL**

**IMPORTANT!** Only attempt to zero gap the blades by using the adjustment tool and following these instructions very precisely. The adjustment tool is required to adjust the blades to zero gap, which will achieve a closer, more precise cut.

**Step 1** – Using the screwdriver included, gently loosen the two small screws on each side of the blade.



**Step 2** – Slide the zero-gap tool over the gold fixed blade until it is tight against the back portion of the moving cutting blade.



**Step 3** – Using your fingers on each side of the zero-gap tool, push up until the black cutting blade is even with or slightly below the gold fixed blade.



Be sure that the blades are aligned properly. The teeth of the smaller blade (cutter) should rest slightly below the upper edge of the larger blade (comb) — approximately 1/64" to 1/32" apart (see Fig. 3). If the blades are not correctly aligned, they may cut or scratch your skin when trimming. Once the blades have been aligned, tighten the screws firmly.

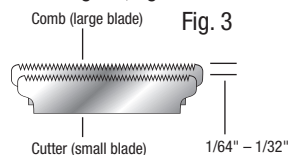

**Step 4** – MAKE SURE THE MOVING CUTTING BLADE DOES NOT EXTEND PAST THE FIXED BLADE. **WARNING: IF THE CUTTING BLADE EXTENDS PAST THE FIXED BLADE YOU CAN POTENTIALLY CUT YOURSELF.**



**Step 5** – Once the blade is adjusted to zero gap or your liking, gently tighten the two screws on each side of the blade while holding the zero gap tool in place. If the blade is not adjusted to satisfaction after testing, repeat the adjusting process.



**BATTERY REMOVAL AND INSTALLATION**

The trimmer features a removable, rechargeable, and interchangeable battery, so you can cut and style for extended amounts of time with minimal interruption. Be sure trimmer is in the OFF ("0") position before removing or installing the battery.

1. To remove the battery, press on the battery release button on the back of the trimmer handle toward the middle of the unit.

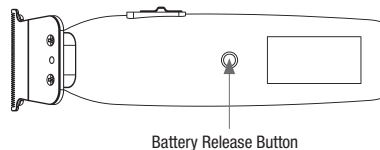

2. The battery will partially eject but needs to be pulled from the bottom of the trimmer to remove completely.

3. To install the battery, line up the keyway of the trimmer with the battery housing, aligning the arrow mark on the battery with the arrow mark on the trimmer. Insert the battery into the opening and push into the housing until the locking mechanism engages.

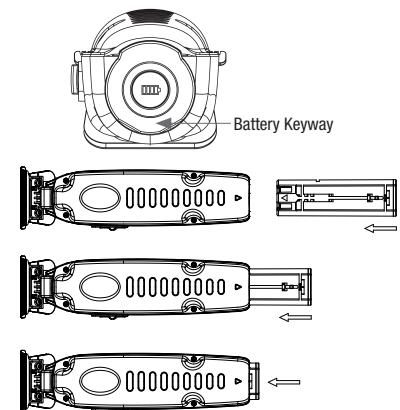

**WARNING** – Make sure the trimmer and battery are aligned properly before pushing battery all the way in. Do not force battery in if any resistance is felt.

**IF YOU HAVE TROUBLE REMOVING BATTERY AFTER PRESSING BATTERY RELEASE BUTTON, INSERT SMALL PIN OR SCREWDRIVER INTO OPENING INDICATED AT RIGHT TO PRY OUT BATTERY.**

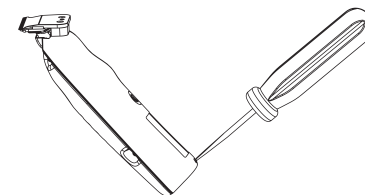

## CHARGING STAND INSTRUCTIONS

The FXONE Universal Battery Charging Stand can be powered by either a universal FXCORD (not included) or the included USB-C cable.

To use the USB-C cable: Connect the USB-C cable to the USB-C port at the back of the FXONE Universal Battery Charging Stand, then insert the battery into the charger.

To use the universal FXCORD: Connect the standard charging cord (FXCORD) to the standard port at the back of the FXONE Universal Battery Charging Stand, then insert the battery into the charger.

To insert the battery into the charging stand: Align the arrow mark on the battery with the arrow mark on the charger, then insert the battery into the opening and push into the housing until the locking mechanism engages.

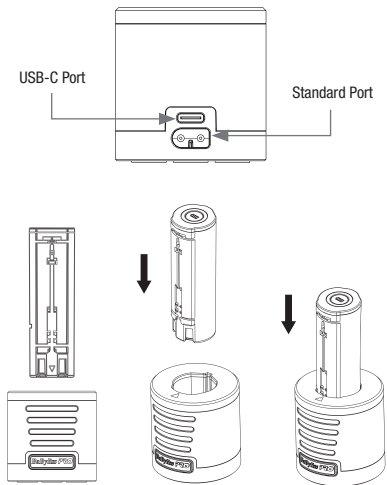

## BATTERY/CHARGING INDICATOR (TOP OF FXONE BATTERY)

Blue flashing – Charging  
Blue solid – Charged (see charge levels below).

- The charging stand may become warm while charging. This is normal.
- Preserving the battery: In order to maintain the optimum capacity of the rechargeable battery, it should be recharged for 3 hours approximately every 6 months.
- Only use with AC adapter CA78M/C045120-AU (not included) or USB adapter CA88M (included).

**WARNING:** If the charging light suddenly starts to flash rapidly, the battery is faulty. If this happens, stop charging, unplug the FXONE Universal Battery Charging Stand from the outlet/USB power source and contact our Customer Care Center for further advice.

## BATTERY CHARGE-LEVEL INDICATOR

The FXONE Universal Battery has a built-in 4-stage LED ring light to indicate charge level of the battery. To check charge level, press on the central button on the bottom of the battery housing to display current charge level.

- Full circle – 100% charge
- $\frac{3}{4}$  circle – 75% charge
- $\frac{1}{2}$  circle – 50% charge
- $\frac{1}{4}$  circle – 25% charge.

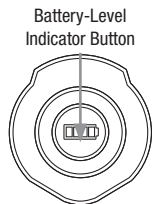

## BATTERY REMOVAL

This trimmer contains lithium-ion batteries. To help protect our environment, the lithium-ion batteries should be removed for safe disposal at the end of the trimmer's life.

Please take the appliance to a recycling center, where the internal rechargeable battery should be removed and recycled separately.



## Li-ion

For more information about recycling of electrical and battery operated appliance, please contact your local office or your household waste disposal service.

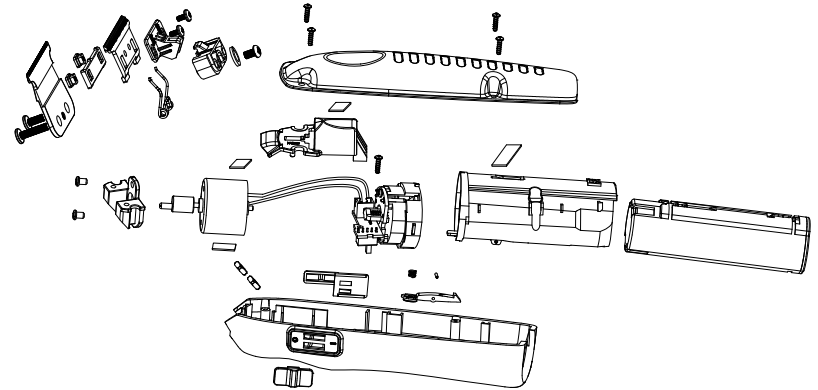

## PROFESSIONAL INTERCHANGEABLE-BATTERY TRIMMER



### PRODUCT FEATURES

- New Ultra-Thin T-Blade
- FXONE Battery (FXBB24A)
- Universal Battery Charging Stand (FXTRAVLA)
- Cleaning Brush
- Lubricating Oil
- Zero-Gap Tool
- Screwdriver
- USB Adapter and USB-C Cable

## TWO YEAR WARRANTY

The warranty may only be claimed where proof of original purchase is presented, i.e. original purchase receipt or invoice. We recommend attaching a copy of your purchase receipt to this instruction book and storing in a safe place.

To make a warranty claim you can return the defective product back to the place it was purchased where it will be replaced, exchanged or repaired (see point 12 in conditions).

Trade purchasers who have purchased from us directly should contact us directly with regard to warranty claims.

Please have the following details to hand:

1. Date of purchase
2. Details of where the product was purchased
3. Product Name/Model Number
4. Confirm you have your purchase receipt
5. Detail the problem with your product

**It is important to retain your proof of purchase. We recommend attaching your receipt to this page.**

For advice with regard to the warranty claim process please contact Customer Services:

### **Dateline Imports P/L Professional Products Division**

Discovery Cove - Unit 8/1801 Botany Road  
Banksmeadow, NSW 2019

Australia

Ph: 61 2 9666 3611

[www.babylisspro.com.au](http://www.babylisspro.com.au)

## **Dateline Imports NZ Ltd**

66 Apollo Drive  
Albany, Auckland  
NZ 0632

Ph: 64 9 415 5415

[www.babylisspro.co.nz](http://www.babylisspro.co.nz)

## **WARRANTY AGAINST DEFECTS**

### **A. AUSTRALIAN CONSUMER LAW**

1. Our goods come with guarantees that cannot be excluded under the Australian Consumer Law. You are entitled to a replacement or refund for a major failure and compensation for any other reasonably foreseeable loss or damage. You are also entitled to have the goods repaired or replaced if the goods fail to be of acceptable quality and the failure does not amount to a major failure.
2. The guarantees under the Australian Consumer Law ("ACL") are provided in sections 51 to 59 inclusive of the ACL ("Statutory Guarantees") and the remedies are provided in sections 259 to 266 inclusive of the ACL ("Statutory Remedies").

In New Zealand our goods come with a guarantee that cannot be excluded under the Consumer Guarantee Act 1993.

### **B. BaBylissPRO EXTENDED WARRANTY**

1. In addition and subject to the Statutory Guarantees and Statutory Remedies, the following express warranty ("Warranty") commences from the date of purchase and continues for a period of 24 months ("Warranty Period") after which it expires. Subject to the conditions in Section C below, Dateline warrants to the original purchaser ("Purchaser") of the BabylissPRO product that is the subject of this warranty ("Product") that if during the Warranty Period, the Product suffers from any defect caused by faults in materials or workmanship, Dateline will a) replace the Product, or b) exchange defective part in the Product or c) repair the Product, as Dateline may choose in its discretion ("Warranty"). In this Warranty "Dateline" means Dateline Imports P/L (ABN 60 000 557 282) of Discovery Cove - Unit 8/1801 Botany Road, Banksmeadow, NSW 2019, Australia.
2. To honour the Warranty, Dateline must replace, or exchange parts in, or repair, the Product, as Dateline determines, in accordance with paragraph B1 above, subject always to the conditions in Section C below.
3. If any of the conditions in Section C below are inconsistent with any provisions of the ACL or regulations made there under, those provisions of the ACL or regulations shall prevail to the extent of the inconsistency.

### **C. CONDITIONS**

1. The Product must be used in accordance with manufacturer's instructions. This Warranty does not apply should the defect in or failure of the Product be attributable to misuse, abuse, accident, unforeseen natural disasters such as lightning etc., or nonobservance of manufacturer's instructions on the part of the user. This Warranty does not cover ordinary wear and tear in the Product or its parts.
2. Dateline does not accept liability for a) any loss or damage however suffered, caused by or arising out of any failure to use the Product in accordance with the manufacturer's instructions, and b) any indirect, consequential or economic loss or damage however caused.
3. This Warranty is immediately void if – a) any serial number or appliance plate is removed or defaced, b) the Product has been serviced or otherwise repaired by a person not authorised to do so by Dateline or where non approved replacement parts are used.
4. The Product must be connected to the electrical voltage supply as specified in the ratings label located on the Product. This Warranty does not cover defects arising from incorrect voltage supply.
5. This Warranty may only be claimed against where proof of original purchase is presented, for example, original receipt or invoice.

- 6. Any parts of the Product that need to be replaced, or if the whole Product needs to be replaced, the replaced Product, become the property of Dateline. The Warranty on any replacement Product or parts will expire on the same date that the Warranty Period on the original Product expires.
- 7. The benefits provided by this Warranty are in addition to all other rights and remedies in respect of the Product which the Purchaser has under the ACL, and applicable laws in New Zealand, which rights and remedies by law may not be excluded. All other warranties and representations express and implied are hereby excluded.
- 8. The defect must have occurred during the Warranty Period and Purchaser bears the onus of proving that fact, and that the defect was not caused by any of the causes excluded from this Warranty.
- 9. This Warranty does not cover Products purchased from any person who is not a retailer serviced by Dateline Imports P/L or purchased second hand.
- 10. The Purchaser is responsible for all postage and freight charges and any other expenses incidental to claiming against this Warranty.
- 11. The Warranty excludes consumable items (such as blades or brushes) and normal wear and tear.

- 12. If you're certain your product is defective, and the product is covered by the terms of this warranty, you need to take the product back to the place you purchased it from, where the retailer will replace the product for you, exchange defective parts, repair the Product or refund at Dateline's discretion. In this event, per the terms of this warranty you will need to present this portion of the warranty information and the purchase receipt as proof of purchase so please make sure you keep both these instructions and your receipt on hand for the duration of the warranty period.